

# Double-Row Ball Bearings Customised Ball Bearings





# Double-row ball bearings and customised ball bearings



## Contents

<b>Page 3</b>	CONTENTS
<b>Page 4</b>	INDIVIDUAL SOLUTIONS
<b>Page 5</b>	PRODUCTS AND APPLICATIONS
<b>Page 6</b>	COMPANY PROFILE
<b>Page 7</b>	STANDARD PRODUCTION PROGRAMME
<b>Page 8</b>	SELF-ALIGNING BALL BEARINGS
<b>Page 10</b>	• Bore 10 – 35 mm
<b>Page 12</b>	• Bore 40 – 75 mm
<b>Page 14</b>	• With adapter sleeve, shaft 17 – 50 mm
<b>Page 16</b>	• With adapter sleeve, shaft 55 – 65 mm
<b>Page 18</b>	• Sealed both ends, bore 12 – 65 mm
<b>Page 20</b>	• With wide inner ring, bore 20 – 60 mm
<b>Page 22</b>	• With sleeve, shaft 20 – 50 mm
<b>Page 24</b>	DEEP-GROOVE BALL BEARING Double-row
<b>Page 36</b>	• Double-row, bore 10 – 90 mm
<b>Page 28</b>	ANGULAR-CONTACT BALL BEARING Double-row
<b>Page 30</b>	• Bore 10 – 75 mm
<b>Page 32</b>	• Double-row, bore 80 – 90 mm
<b>Page 34</b>	• Double-row, with filling slot, bore 10 – 70 mm
<b>Page 36</b>	PULLEYS
<b>Page 38</b>	• Pulleys, bore 10 – 35 mm
<b>Page 39</b>	Life factors $F_h$ and speed factors $F_n$ for ball bearings

## Flexible variation – solid precision

Everything is possible. NSK special bearings are manufactured according to your specific requirements. The only thing 'standard' with all our products is the NSK Quality.

**Internal design for load ratings:**  
DIN/ISO 76  
DIN/ISO 281

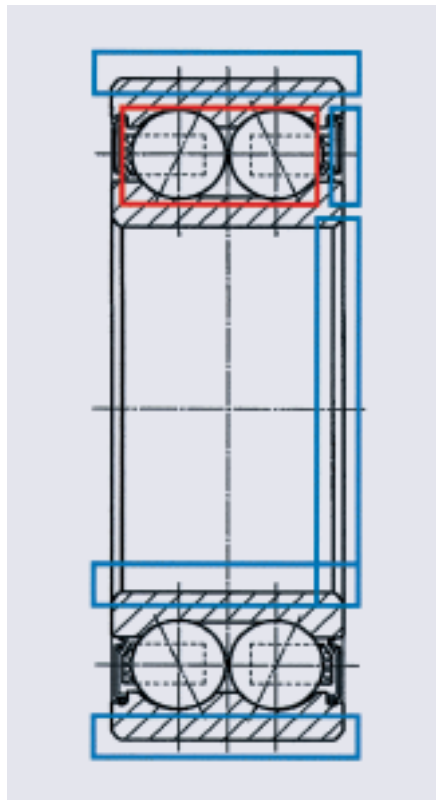

### OUTER RING ACCORDING TO CUSTOMER REQUIREMENTS

- Diameter
- Width
- With groove
- With bore/thread

#### Profile

- Spherical
- Gothic arch
- V-profile
- Groove turned or ground

### SEALS ACCORDING TO CUSTOMER REQUIREMENTS

#### Standard

- ZR/2ZR
- RSR/2RSR

#### Special solutions

- Multi-lipped
- Labyrinth seal
- Three-part sealing

### INNER RING ACCORDING TO CUSTOMER REQUIREMENTS

#### Bore

- Diameter
- Cone
- Teeth
- Groove
- Thread

#### Width



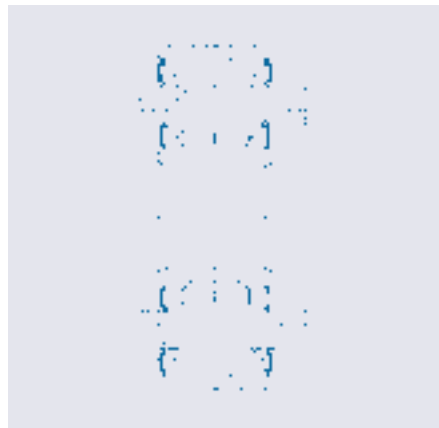

**DOUBLE-ROW BALL BEARINGS**

30 mm...180 mm external diameter (deep-groove, angular-contact and self-aligning ball bearings and various versions)

**Deep-groove ball bearings in:**

- WHEEL BEARINGS
- BELT-TENSIONERS
- FANS

**Angular-contact ball bearings in:**

- THE AUTOMOBILE INDUSTRY
- SHAFT ENCODERS
- GEARBOXES
- WOOD PROCESSING MACHINES
- COMPRESSORS
- MAST GUIDE ROLLERS
- PUMPS
- WHEEL BEARINGS
- BELT-TENSIONERS
- TACHOMETERS

**Self-aligning ball bearings in:**

- BLOWERS
- WOOD PROCESSING MACHINES
- AGRICULTURAL MACHINES
- EXTRACTION FANS
- TEXTILE MACHINES
- ROLLERS

**DOUBLE-ROW CUSTOMISED BALL BEARINGS**

for applications such as the in-house design of double-row clutch-release bearings based on standard bearing or new designs:

- WIRE-STRAIGHTENING MACHINES
- ELECTROMAGNETIC CLUTCHES (FOR EXAMPLE)
- CONVEYOR EQUIPMENT
- LIFTING EQUIPMENT
- WOOD-PROCESSING MACHINES
- CHAIN PULLEYS
- PULLEYS
- PULLEYS FOR OVERHEAD CHAIN CONVEYORS
- LINEAR GUIDES
- ROPE PULLEYS
- ALL TYPES OF TENSION PULLEYS

**RADIAL INSERT BEARING WITH OUTER RING**

for harvesting machines (special designs, suitable for applications where there is high exposure to contamination and for high-pressure cleaning)

- CONVEYOR BELTS
- HOUSED BEARING UNITS
- CHAIN CONVEYORS
- AGRICULTURAL MACHINES
- SUPPORT ROLLERS
- FANS



## Quality – made in Germany

Our products are manufactured in Germany to a high standard of quality and reliability, and our management system is certified in accordance with national and international standards. We take responsibility for our total process – when it comes to the environment, too: We take it for granted that raw materials and energy must be used efficiently and that waste must be reduced to the minimum.

Certification according to  
**ISO/TS 16949:2002** including  
**DIN EN ISO 9001:2000** and  
**DIN EN ISO 14001:2004**

Are you looking for something special? At NSK, you will find experts in all of our sales offices. When it comes to meeting your requirements – whether they are standard or special solutions - our staff are always at your service. The only thing we do not need to discuss is quality. With us, meeting the highest standards is the norm.



## Always at your service

### Europe

PETERLEE  
 COVENTRY  
 MAIDENHEAD  
 NEWARK  
 RATINGEN  
 STUTTGART  
 MUNDERKINGEN  
 PARIS  
 BARCELONA  
 TURIN  
 MILAN  
 WARSAW  
 KIELCE  
 WALBRZYCH  
 ISTANBUL

### Africa

JOHANNESBURG

### North America

MONTREAL  
 ANN ARBOR  
 FRANKLIN  
 PLAINFIELD  
 CLARINDA  
 MIAMI  
 SANTA FE SPRINGS  
 VANCOUVER

### South America

BUENOS AIRES  
 SUZANO  
 SAO PAULO  
 MEXICO CITY

### New Zealand Australia

AUCKLAND  
 SYDNEY  
 BRISBANE  
 MELBOURNE  
 ADELAIDE  
 PERTH

### Asia

HONG KONG  
 BEIJING  
 SHANGHAI  
 KUNSHAN  
 SEOUL  
 TOKYO  
 FUJISAWA  
 TAIPEH  
 MANILA  
 HANOI  
 BANGKOK  
 KUALA LUMPUR  
 SINGAPORE  
 JAKARTA



BASIC TYPES	OPEN	ZR	ZZR	RSR	2RSR	N NR	K	TNG-CAGE	J-CAGE	C2 C3
1201 – 1203	●							●	○	●
1204 – 1213	●						●	●	○	●
1214	○						○	○	○	○
1215	●						●	●	○	●
1302 – 1303	●							●	○	●
1304 – 1311	●						●	●	○	●
1312	●						●		●	●
2201 – 2203	●				●			●	○	●
2204 – 2213	●				●		●	●	○	●
2302 – 2303	●				●			●	○	●
2304	●						●		●	●
2304	●				●			●		●
2305 – 2313	●				●		●	●	○	●
2314	●						●		●	●
11204 – 11212	●							●	○	●
11305 – 11310	●							●	○	●
11504 – 11510	●							●	○	●
3200B – 3218B	●	●	●	●	●	●		●		●
3301B – 3315B	●	●	●	●	●	●		●		●
3200 – 3214	○								○	○
3302 – 3313	○								○	○
3314	●					●			●	●
LB3200B – LB3207B			●		●			●		
LZ3200B – LZ3207B			●		●			●		
4200 – 4218	●							●	○	●
4302 – 4315	●							●	○	●

● Special bearings on enquiry  
 ● Standard  
 ○ on enquiry

# Self-aligning ball bearings

Self-aligning ball bearings are double-row bearings with a spherical outer ring raceway. The bearings therefore facilitate angle adjustment and are suitable for compensating for angular misalignment.

Self-aligning ball bearings are manufactured with cylindrical and tapered bores. The bearings with tapered bore are predominantly fitted to shafts with adapter sleeves. The cages of these bearings are normally made of glass-fibre reinforced Polyamide 66. Bearings with these cages are marked with the designation "TNG". The cages of some of the small bearings are made of Polyamide 66 without glass-fibre reinforcement. These are marked with the designation "TN".

A very few bearings (Version J) are mass produced with cages made of pressed steel. The bearings which are normally fitted with plastic cages are also available on request with cages made of pressed steel "J".

Series 22.. and 23.. self-aligning bearings are also available sealed on both sides. These bearings are marked with the designation "2RS".

## Standards, dimensions

The external dimensions of self-aligning ball bearings are laid down in ISO R15 or DIN 630.

## Tolerances

The bearings are only manufactured to the standard tolerance P0.

## Bearing clearance

Self-aligning bearings with cylindrical bores are normally manufactured with standard radial clearance C0 and those with a tapered bore with radial clearance C3. Bearings with other clearances are available on enquiry.

The clearances can be found in the table below.

Radial bearing clearance of self-aligning ball bearings with cylindrical bore without load according to DIN 620, Part 4

Rated size of bore (mm)	above	6	10	14	18	24	30	40	50
	up to	10	14	18	24	30	40	50	65
C2	min.	2	2	3	4	5	6	6	7
	max.	9	10	12	14	16	18	19	21
C0 Standard	min.	6	6	8	10	11	13	14	16
	max.	17	19	21	23	24	29	31	36
C3	min.	12	13	15	17	19	23	25	30
	max.	25	26	28	30	35	40	44	50
C4	min.	19	21	23	25	29	34	37	45
	max.	33	35	37	39	46	53	57	69
C5	min.	27	30	32	34	40	46	50	62
	max.	42	48	50	52	58	66	71	88

Bearing clearances in µm

Radial bearing clearance of self-aligning ball bearings with tapered bore without load according to DIN 620, Part 4

Rated size of bore (mm)	above	18	24	30	40	50
	up to	24	30	40	50	65
C2	min.	7	9	12	14	18
	max.	17	20	24	27	32
C0	min.	13	15	19	22	27
	max.	26	28	35	39	47
C3 Standard	min.	20	23	29	33	41
	max.	33	39	46	52	61
C4	min.	28	33	40	45	56
	max.	42	50	59	65	80
C5	min.	37	44	52	58	73
	max.	55	62	72	79	99

Bearing clearances in  $\mu\text{m}$

**Seals** NSK manufactures Series 22.. and 23.. self-aligning ball bearings, not only open version but also with seals on both sides of the bearing. These seals are made of nitrile rubber and are reinforced with a steel disc embedded in the rubber. The seals are fixed in the outer ring and seal against the inner ring with a friction sealing lip.

Sealed self-aligning ball bearings are filled with enough grease at the factory to last the normal life span of the bearing. The bearings are therefore maintenance free. Note that sealed self-aligning bearings have a lower load-carrying capacity than open bearings of the same type. During installation, it is essential that they are not twisted, as otherwise the seals may be forced out of position.

**Angle adjustment facility** Self-aligning bearings facilitate angle adjustment. The permitted angle of tilt from the central position for Series 12.. and 22.. open bearings is  $2.5^\circ$  and for Series 13.. and 23.. is  $3^\circ$ . With sealed bearings, the permitted angle of tilt is  $1.5^\circ$ .

**Dynamic equivalent bearing load**  $P = F_r + Y_1 \cdot F_a$  [kN] for  $F_a/F_r \leq e$   
 $P = 0.65 \cdot F_r + Y_2 \cdot F_a$  [kN] for  $F_a/F_r > e$   
 The factors  $e$ ,  $Y_1$  and  $Y_2$  can be found in the bearing tables.

**Basic rating life**  $L_h = \frac{1,000,000}{n \cdot 60} \cdot \left(\frac{C}{P}\right)^3$  (Running hours)  
 $f_h = f_n \cdot \left(\frac{C}{P}\right)$  (Factors  $f_h$  and  $f_n$ , see tables on Page 39)

**Static equivalent bearing load**  $P_0 = F_r + Y_0 \cdot F_a$  [kN]  
 The factor  $Y_0$  can be found in the bearing tables.

**Basic static load rating**  $S_0 = \left(\frac{C_0}{P_0}\right)$

# Self-aligning ball bearings

Cylindrical bore

Bore 10 – 35 mm



Dimensions				Abbreviation for		Load ratings		Speed limits	
d	D	B	$r_{1,2}$ min	cylindrical bore	Tapered bore	dyn. C	stat. C <sub>0</sub>	Grease	Oil
mm						kN		min <sup>-1</sup>	
10	30	9	0.6	1200TN	—	5.50	1.53	24,000	30,000
	30	14	0.6	2200TN	—	7.20	2.04	24,000	30,000
12	32	10	0.6	1201TNG	—	5.60	1.27	24,000	30,000
	32	14	0.6	2201ETNG	—	9.00	1.96	20,000	26,000
	37	12	1.0	1301TN	—	9.50	2.16	18,000	22,000
15	35	11	0.6	1202TNG	—	7.50	1.76	20,000	26,000
	35	14	0.6	2202ETNG	—	9.15	2.08	19,000	24,000
	42	13	1.0	1302TN	—	9.50	2.28	17,000	20,000
	42	17	1.0	2302ETNG	—	12.00	2.90	16,000	19,000
17	40	12	0.6	1203TNG	—	8.00	2.04	18,000	22,000
	40	16	0.6	2203ETNG	—	11.40	2.75	16,000	19,000
	47	14	1.0	1303TN	—	12.50	3.20	15,000	18,000
	47	19	1.0	2303TN	—	14.30	3.55	14,000	17,000
20	47	14	1.0	1204TNG	1204KTNGC3	10.00	2.65	15,000	18,000
	47	18	1.0	2204ETNG	2204EKTNGC3	14.30	3.55	14,000	17,000
	52	15	1.1	1304TNG	1304KTNGC3	12.50	3.35	13,000	16,000
	52	21	1.1	2304J	2304KJC3	18.00	4.65	13,000	16,000
25	52	15	1.0	1205TNG	1205KTNGC3	12.20	3.35	13,000	16,000
	52	18	1.0	2205ETNG	2205EKTNGC3	17.00	4.40	12,000	15,000
	62	17	1.1	1305TNG	1305KTNGC3	18.00	5.00	11,000	14,000
	62	24	1.1	2305TNG	2305KTNGC3	24.50	6.55	10,000	13,000
30	62	16	1.0	1206TNG	1206KTNGC3	15.60	4.65	11,000	14,000
	62	20	1.0	2206ETNG	2206EKTNGC3	25.50	6.95	9,500	12,000
	72	19	1.1	1306TNG	1306KTNGC3	21.20	6.30	9,000	11,000
	72	27	1.1	2306TNG	2306KTNGC3	31.50	8.65	8,500	10,000
35	72	17	1.1	1207TNG	1207KTNGC3	16.00	5.20	9,500	12,000
	72	23	1.1	2207ETNG	2207EKTNGC3	32.00	9.00	8,000	9,500
	80	21	1.5	1307TNG	1307KTNGC3	25.00	8.00	8,000	9,500
	80	31	1.5	2307TNG	2307KTNGC3	39.00	11.20	7,500	9,000

Tapered bore (Taper 1:12)

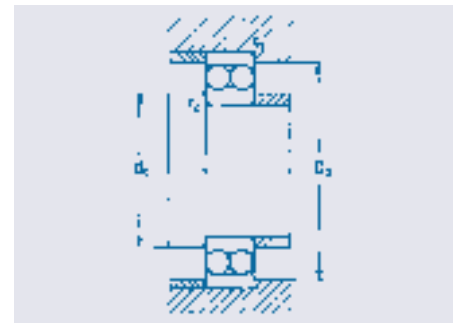
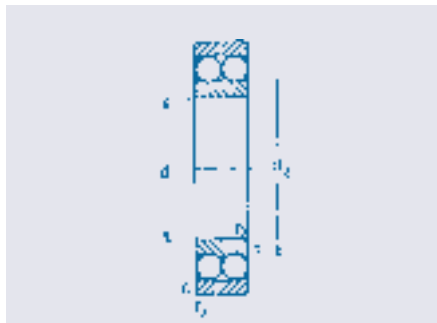
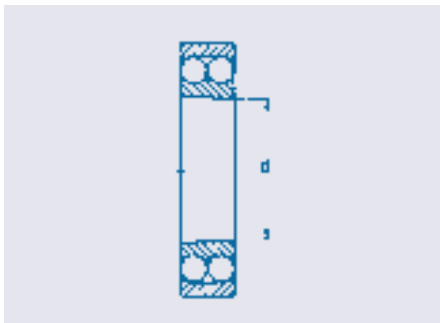

Abutment dimensions			Factors				Weight	Abbreviation
$d_a$ min	$D_a$ max	$r_a$ max	e	$Y_1$ $Fa/Fr \leq e$	$Y_2$ $Fa/fr > e$	$Y_0$	$\approx$	
mm							kg	
14.0	26.0	0.6	0.32	2.0	3.00	2.1	0.034	1200TN
14.0	26.0	0.6	0.66	1.0	1.50	1.0	0.047	2200TN
16.0	28.0	0.6	0.37	1.7	2.60	1.8	0.040	1201TNG
16.0	28.0	0.6	0.53	1.2	1.85	1.3	0.053	2201ETNG
17.0	32.0	1.0	0.35	1.8	2.80	1.9	0.067	1301TN
19.0	31.0	0.6	0.34	1.9	2.90	2.0	0.049	1202TNG
19.0	31.0	0.6	0.46	1.4	2.10	1.4	0.060	2202ETNG
20.0	37.0	1.0	0.35	1.8	2.80	1.9	0.094	1302TN
20.0	37.0	1.0	0.51	1.2	1.90	1.3	0.110	2302ETNG
21.0	36.0	0.6	0.33	1.9	3.00	2.0	0.073	1203TNG
21.0	36.0	0.6	0.46	1.4	2.10	1.4	0.088	2203ETNG
22.0	42.0	1.0	0.32	1.9	3.00	2.0	0.130	1303TN
22.0	42.0	1.0	0.53	1.2	1.90	1.3	0.160	2303TN
25.0	42.0	1.0	0.28	2.2	3.50	2.3	0.120	1204TNG
25.0	42.0	1.0	0.44	1.5	2.20	1.5	0.140	2204ETNG
26.5	45.5	1.0	0.29	2.2	3.30	2.3	0.160	1304TNG
26.5	45.5	1.0	0.51	1.2	1.90	1.3	0.210	2304J
30.0	47.0	1.0	0.27	2.4	3.70	2.5	0.140	1205TNG
30.0	47.0	1.0	0.35	1.8	2.80	1.9	0.160	2205ETNG
31.5	55.5	1.0	0.28	2.3	3.50	2.4	0.260	1305TNG
31.5	55.5	1.0	0.48	1.3	2.00	1.4	0.340	2305TTNG
35.0	57.0	1.0	0.25	2.5	3.90	2.7	0.220	1206TNG
35.0	57.0	1.0	0.30	2.1	3.30	2.2	0.260	2206ETNG
36.5	65.5	1.0	0.26	2.4	3.70	2.5	0.390	1306TNG
36.5	65.5	1.0	0.45	1.4	2.20	1.5	0.500	2306TNG
41.5	65.5	1.0	0.22	2.8	4.30	2.9	0.320	1207TNG
41.5	65.5	1.0	0.30	2.1	3.30	2.2	0.400	2207ETNG
43.0	72.0	1.5	0.26	2.5	3.80	2.6	0.510	1307TNG
43.0	72.0	1.5	0.47	1.4	2.10	1.4	0.680	2307TNG

# Self-aligning ball bearings

Cylindrical bore

Bore 40 – 75 mm



Dimensions				Abbreviation for		Load ratings		Speed limits	
d	D	B	r <sub>1,2</sub> min	cylindrical bore	Tapered bore	dyn. C	stat. C <sub>0</sub>	Grease	Oil
mm						kN		min <sup>-1</sup>	
40	80	18	1.1	1208TNG	1208KTNGC3	19.30	6.55	8,500	10,000
	80	23	1.1	2208ETNG	2208EKTNGC3	31.50	9.50	7,500	9,000
	90	23	1.5	1308TNG	1308KTNGC3	29.00	9.65	7,000	8,500
	90	33	1.5	2308TNG	2308KTNGC3	45.00	13.40	6,700	8,000
45	85	19	1.1	1209TNG	1209KTNGC3	22.00	7.35	7,500	9,000
	85	23	1.1	2209ETNG	2209EKTNGC3	28.00	9.00	7,000	8,500
	100	25	1.5	1309TNG	1309KTNGC3	38.00	12.90	6,300	7,500
	100	36	1.5	2309TNG	2309KTNGC3	54.00	16.30	6,000	7,000
50	90	20	1.1	1210TNG	1210KTNGC3	22.80	8.15	7,000	8,500
	90	23	1.1	2210ETNG	2210EKTNGC3	28.00	9.50	6,700	8,000
	110	27	2.0	1310TNG	1310KTNGC3	41.50	14.30	5,600	6,700
	110	40	2.0	2310TNG	2310KTNGC3	64.00	20.00	5,300	6,300
55	100	21	1.5	1211TNG	1211KTNGC3	27.00	10.00	6,300	7,500
	100	25	1.5	2211ETNG	2211EKTNGC3	39.00	12.70	5,600	6,700
	120	29	2.0	1311TNG	1311KTNGC3	51.00	18.00	5,000	6,000
	120	43	2.0	2311TNG	2311KTNGC3	75.00	23.60	4,800	5,600
60	110	22	1.5	1212TNG	1212KTNGC3	30.00	11.60	5,600	6,700
	110	28	1.5	2212ETNG	2212EKTNGC3	47.50	16.60	5,300	6,300
	130	31	2.0	1312J	1312KJC3	57.50	20.80	4,800	5,600
	130	46	2.0	2312J	2312KJC3	88.50	28.30	4,300	5,300
65	120	23	1.5	1213TNG	1213KTNGC3	31.00	12.50	5,300	6,300
	120	31	1.5	2213ETNG	2213EKTNGC3	57.00	19.30	4,500	5,300
	140	33	2.1	1313J	1313KTNGC3	62.50	22.90	4,300	5,300
	140	48	2.1	2313J	2313KTNGC3	96.50	32.50	4,000	4,800
70	125	24	1.5	1214TNG	—	34.50	13.70	5,000	6,000
	125	31	1.5	2214J	—	44.00	17.10	4,500	5,600
	150	35	2.1	1314J	—	67.50	25.10	4,000	5,000
	150	51	2.1	2314J	—	111.00	37.50	3,600	4,300
75	130	25	1.5	1215TNG	1215KTNGC3	39.00	15.60	4,800	5,600
	130	31	1.5	2215J	2215KJC3	44.50	17.80	4,300	5,300
	160	37	2.1	1315J	1315KJC3	80.00	30.00	3,800	4,500
	160	55	2.1	2315J	2315KJC3	125.00	43.00	3,400	4,300

Tapered bore (Taper 1:12)

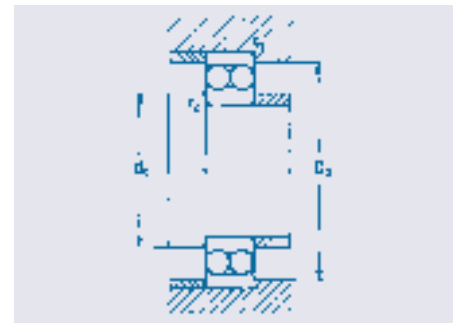
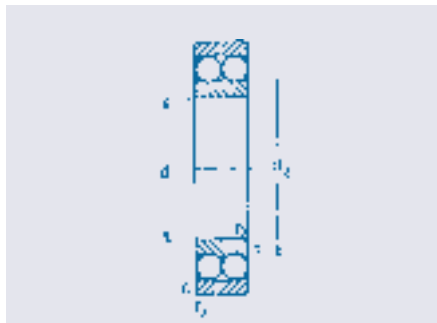
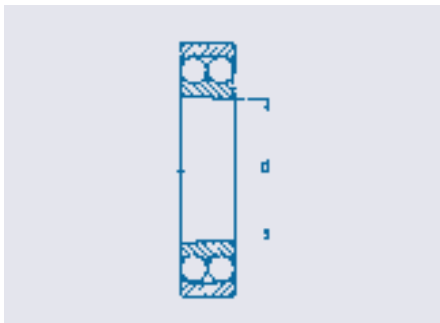

Abutment dimensions			Factors				Weight	Abbreviation
$d_a$ min	$D_a$ max	$r_a$ max	e	$Y_1$ $Fa/Fr \leq e$	$Y_2$ $Fa/fr > e$	$Y_0$	$\approx$	
mm							kg	
46.5	73.5	1.0	0.22	2.9	4.5	3.0	0.42	1208TNG
46.5	73.5	1.0	0.26	2.4	3.8	2.5	0.51	2208ETNG
48.0	82.0	1.5	0.25	2.5	3.9	2.6	0.72	1308TNG
48.0	82.0	1.5	0.43	1.5	2.3	1.5	0.93	1208TNG
51.5	78.5	1.0	0.21	3.0	4.7	3.2	0.47	1209TNG
51.5	78.5	1.0	0.26	2.4	3.8	2.5	0.55	2209ETNG
53.0	92.0	1.5	0.25	2.5	3.9	2.6	0.96	1309TNG
53.0	92.0	1.5	0.43	1.5	2.3	1.6	1.25	2309TNG
56.5	83.5	1.0	0.19	3.2	4.9	3.3	0.53	1210TNG
56.5	83.5	1.0	0.22	2.6	4.1	3.7	0.59	2210ETNG
59.0	101.0	2.0	0.24	2.6	4.0	2.7	1.20	1310TNG
59.0	101.0	2.0	0.43	1.5	2.3	1.5	1.65	2310TNG
63.0	92.0	1.5	0.19	3.3	5.1	3.5	0.71	1211TNG
63.0	92.0	1.5	0.22	2.9	4.5	2.1	0.81	2211ETNG
64.0	111.0	2.0	0.24	2.7	4.1	2.8	1.60	1311TNG
64.0	111.0	2.0	0.42	1.5	2.3	1.6	2.10	2311TNG
68.5	101.5	1.5	0.18	3.5	5.4	3.6	0.90	1212TNG
68.5	101.5	1.5	0.23	2.7	4.2	2.8	1.10	2212ETNG
72.0	118.0	2.0	0.23	2.8	4.3	2.9	1.95	1312TNG
72.0	118.0	2.0	0.40	1.6	2.4	1.7	2.60	2312TNG
73.0	112.0	1.5	0.18	3.6	5.5	3.7	1.15	1213TNG
73.0	112.0	1.5	0.23	2.8	4.3	2.9	1.45	2213ETNG
76.0	128.0	2.0	0.23	2.8	4.3	2.9	2.45	1313J
76.0	128.0	2.0	0.39	1.6	2.5	1.7	3.25	2313J
78.0	116.5	1.5	0.19	3.3	5.1	3.5	1.25	1214TNG
78.0	116.5	1.5	0.26	2.4	3.7	2.5	1.50	2214J
81.0	138.0	2.0	0.22	2.8	4.4	3.0	3.00	1314J
81.0	138.0	2.0	0.38	1.7	2.6	1.8	4.25	2314J
83.5	121.5	1.5	0.17	3.6	5.6	3.8	1.35	1215TNG
83.5	121.5	1.5	0.25	2.5	3.9	2.6	1.60	2215J
87.0	148.0	2.0	0.22	2.8	4.4	3.0	3.55	1315J
87.0	148.0	2.0	0.38	1.6	2.6	1.7	5.15	2315J

# Self-aligning ball bearings

With adapter sleeve  
Shaft 17 – 50 mm

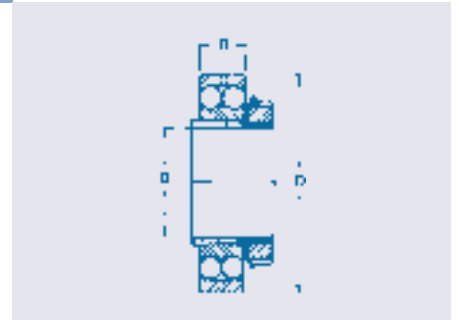

Dimensions				Abbreviation		Load ratings		Speed limits	
d <sub>1</sub>	D	B	r <sub>1,2</sub>	Bearing	Sleeve	dyn.	stat.	Grease	Oil
Shaft			min			C	C <sub>0</sub>		
mm						kN		min <sup>-1</sup>	
17	47	14	1.0	1204KTNGC3	H204	10.00	2.65	15,000	18,000
	47	18	1.0	2204EKTNGC3	H304	14.30	3.55	14,000	17,000
	52	15	1.1	1304KTNGC3	H304	12.50	3.35	13,000	16,000
	52	21	1.1	2304KJJC3	H2304	18.00	4.65	13,000	16,000
20	52	15	1.0	1205KTNGC3	H205	12.20	3.35	13,000	16,000
	52	18	1.0	2205EKTNGC3	H305	17.00	4.40	12,000	15,000
	62	17	1.1	1305KTNGC3	H305	18.00	5.00	11,000	14,000
	62	24	1.1	2305KTNGC3	H2305	24.50	6.55	10,000	13,000
25	62	16	1.0	1206KTNGC3	H206	15.60	4.65	11,000	14,000
	62	20	1.0	2206EKTNGC3	H306	25.50	6.95	9,500	12,000
	72	19	1.1	1306KTNGC3	H306	21.20	6.30	9,000	11,000
	72	27	1.1	2306KTNGC3	H2306	31.50	8.65	8,500	10,000
30	72	17	1.1	1207KTNGC3	H207	16.00	5.20	9,500	12,000
	72	23	1.1	2207EKTNGC3	H307	32.00	9.00	8,000	9,500
	80	21	1.5	1307KTNGC3	H307	25.00	8.00	8,000	9,500
	80	31	1.5	2307KTNGC3	H2307	39.00	11.20	7,500	9,000
35	80	18	1.1	1208KTNGC3	H208	19.30	6.55	8,500	10,000
	80	23	1.1	2208EKTNGC3	H308	31.50	9.50	7,500	9,000
	90	23	1.5	1308KTNGC3	H308	29.00	9.65	7,000	8,500
	90	33	1.5	2308KTNGC3	H2308	45.00	13.40	6,700	8,000
40	85	19	1.1	1209KTNGC3	H209	22.00	7.35	7,500	9,000
	85	23	1.1	2209EKTNGC3	H309	28.00	9.00	7,000	8,500
	100	25	1.5	1309KTNGC3	H309	38.00	12.90	6,300	7,500
	100	36	1.5	2309KTNGC3	H2309	54.00	16.30	6,000	7,000
45	90	20	1.1	1210KTNGC3	H210	22.90	8.15	7,000	8,500
	90	23	1.1	2210EKTNGC3	H310	28.00	9.50	6,700	8,000
	110	27	2.0	1310KTNGC3	H310	41.50	14.30	5,600	6,700
	110	40	2.0	2310KTNGC3	H2310	64.00	20.00	5,300	6,300
50	100	21	1.5	1211KTNGC3	H211	27.00	10.00	6,300	7,500
	100	25	1.5	2211EKTNGC3	H311	39.00	12.70	5,600	6,700
	120	29	2.0	1311KTNGC3	H311	51.00	18.00	5,000	6,000
	120	43	2.0	2311KTNGC3	H2311	75.00	23.60	4,800	5,600

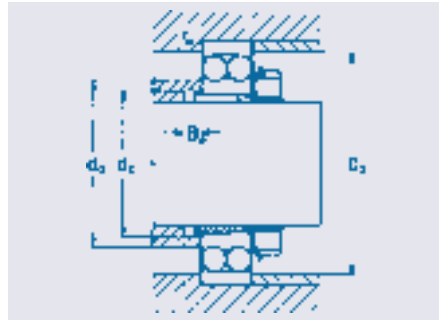
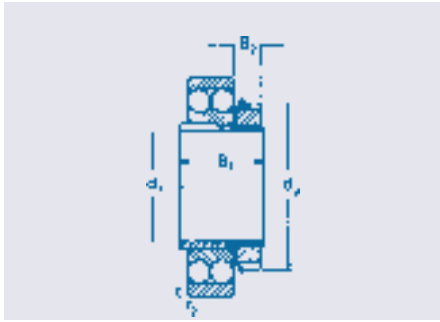

Dimensions			Abutment dimensions					Factors				Weight		Abbreviation
$d_3$	$B_1$	$B_2$	$d_a$	$d_b$	$D_a$	$B_a$	$r_a$	$e$	$Y_1$	$Y_2$	$Y_0$	Bearing	Sleeve	≈
			max	min	max	min	max	$Fa/Fr \leq e$ $Fa/fr > e$						
mm			mm									kg		
32	24	7	27	23	42.0	5	1.0	0.28	2.2	3.5	2.3	0.12	0.041	1204KTNGC3
32	28	7	27	23	42.0	5	1.0	0.44	1.5	2.2	1.5	0.14	0.045	2204EKTNGC3
32	28	7	30	23	45.5	8	1.0	0.29	2.2	3.3	2.3	0.16	0.045	1304KTNGC3
32	31	7	28	24	45.5	5	1.0	0.51	1.2	1.9	1.3	0.21	0.049	2304KJJC3
38	26	8	32	28	47.0	5	1.0	0.27	2.4	3.7	2.5	0.14	0.070	1205KTNGC3
38	29	8	32	28	47.0	5	1.0	0.35	1.8	2.8	1.9	0.16	0.075	2205EKTNGC3
38	29	8	35	28	55.5	6	1.0	0.28	2.3	3.5	2.4	0.26	0.075	1305KTNGC3
38	35	8	34	30	55.5	5	1.0	0.48	1.3	2.0	1.4	0.34	0.087	2305KTNGC3
45	27	8	38	33	57.0	5	1.0	0.25	2.5	3.9	2.7	0.22	0.100	1206KTNGC3
45	31	8	39	33	57.0	5	1.0	0.30	2.1	3.3	2.2	0.24	0.110	2206EKTNGC3
45	31	8	42	33	65.5	6	1.0	0.26	2.4	3.7	2.5	0.38	0.110	1306KTNGC3
45	38	8	40	35	65.5	5	1.0	0.45	1.4	2.2	1.5	0.49	0.130	2306KTNGC3
52	29	9	45	38	65.5	5	1.0	0.22	2.8	4.3	2.9	0.32	0.130	1207KTNGC3
52	35	9	44	39	65.5	5	1.0	0.30	2.1	3.3	2.2	0.40	0.140	2207EKTNGC3
52	35	9	49	39	72.0	7	1.5	0.26	2.5	3.8	2.6	0.50	0.140	1307KTNGC3
52	43	9	45	40	72.0	5	1.5	0.47	1.4	2.1	1.4	0.66	0.170	2307KTNGC3
58	31	10	52	43	73.5	6	1.0	0.22	2.9	4.5	3.0	0.41	0.170	1208KTNGC3
58	36	10	50	44	73.5	6	1.0	0.26	2.4	3.8	2.5	0.49	0.190	2208EKTNGC3
58	36	10	55	44	82.0	6	1.5	0.25	2.5	3.9	2.6	0.70	0.190	1308KTNGC3
58	46	10	51	45	82.0	6	1.5	0.43	1.5	2.3	1.5	0.90	0.220	2308KTNGC3
65	33	11	57	48	78.5	6	1.0	0.21	3.0	4.7	3.2	0.46	0.230	1209KTNGC3
65	39	11	56	50	78.5	8	1.0	0.26	2.4	3.8	2.5	0.53	0.250	2209EKTNGC3
65	39	11	61	50	92.0	6	1.5	0.25	2.5	3.9	2.6	0.94	0.250	1309KTNGC3
65	50	11	57	50	92.0	6	1.5	0.43	1.5	2.3	1.6	1.20	0.280	2309KTNGC3
70	35	12	62	53	83.5	6	1.0	0.20	3.2	4.9	3.3	0.52	0.270	1210KTNGC3
70	42	12	61	55	83.5	10	1.0	0.24	2.6	4.1	2.7	0.58	0.300	2210EKTNGC3
70	42	12	68	55	101.0	6	2.0	0.24	2.6	4.0	2.7	1.20	0.300	1310KTNGC3
70	55	12	63	56	101.0	6	2.0	0.43	1.5	2.3	1.5	1.60	0.360	2310KTNGC3
75	37	12	69	60	92.0	7	1.5	0.19	3.3	5.1	3.5	0.69	0.310	1211KTNGC3
75	45	12	68	60	92.0	11	1.5	0.22	2.9	4.5	2.1	0.79	0.390	2211EKTNGC3
75	45	12	74	60	111.0	7	2.0	0.24	2.7	4.1	2.8	1.55	0.390	1311KTNGC3
75	59	12	69	61	111.0	7	2.0	0.42	1.5	2.3	1.6	2.05	0.420	2311KTNGC3

# Self-aligning ball bearings

With adapter sleeve  
Shaft 55 – 65 mm

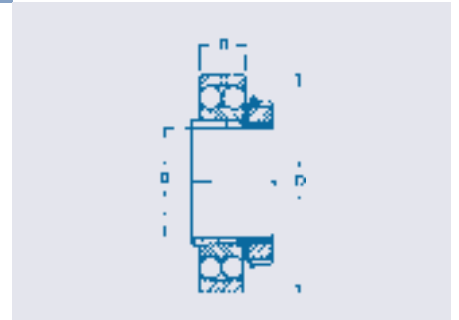

Dimensions				Abbreviation		Load ratings		Speed limits	
d <sub>1</sub> Shaft	D	B	r <sub>1,2</sub> min	Bearing	Sleeve	dyn. C	stat. C <sub>0</sub>	Grease	Oil
mm						kN		min <sup>-1</sup>	
55	110	22	1.5	1212KTNGC3	H212	30.0	11.6	5,600	6,700
	110	28	1.5	2212EKTNGC3	H312	47.5	16.6	5,300	6,300
	130	31	2.0	1312KJC3	H312	57.5	20.8	4,800	5,600
	130	46	2.0	2312KJC3	H2312	88.5	28.3	4,300	5,300
60	120	23	1.5	1213KTNGC3	H213	31.0	12.5	5,300	6,300
	120	31	1.5	2213EKTNGC3	H313	57.0	19.3	4,500	5,300
	140	33	2.1	1313KJC3	H313	62.5	22.9	4,300	5,300
	140	48	2.1	2313KJC3	H2313	96.5	32.5	4,000	4,800
65	130	25	1.5	1215KTNGC3	H215	39.0	15.6	4,800	5,600
	130	31	1.5	2215KJC3	H315	44.5	17.8	4,300	5,300
	160	37	2.1	1315KJC3	H315	80.0	30.0	3,800	4,500
	160	55	2.1	2315KJC3	H2315	125.0	43.0	3,400	4,300

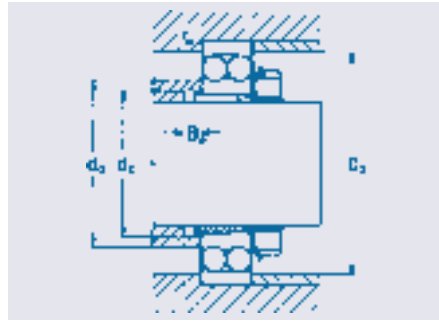
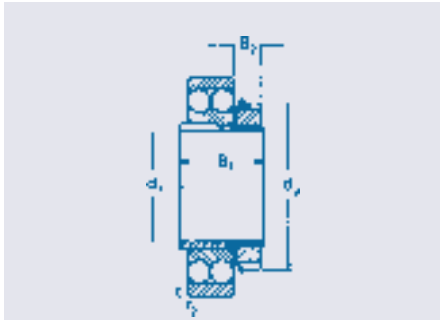

Dimensions			Abutment dimensions					Factors				Weight		Abbreviation
$d_3$	$B_1$	$B_2$	$d_a$	$d_b$	$D_a$	$B_a$	$r_a$	$e$	$Y_1$	$Y_2$	$Y_0$	Bearing	Sleeve	$\approx$
			max	min	max	min	max		$F_a/F_r \leq e$	$F_a/f_r > e$				
mm			mm									kg		
80	38	13	75	64	102	7	1.5	0.18	3.5	5.4	3.6	0.90	0.35	1212KTNGC3
80	47	13	73	65	102	9	1.5	0.23	2.7	4.2	2.8	1.10	0.39	2212EKTNGC3
80	47	13	83	65	119	7	2.0	0.23	2.8	4.3	2.9	1.95	0.39	1312KJJC3
80	62	13	74	66	119	7	2.0	0.40	1.6	2.4	1.7	2.60	0.49	2312KJJC3
85	40	14	83	70	112	7	1.5	0.18	3.6	5.5	3.7	1.15	0.40	1213KTNGC3
85	50	14	79	70	112	9	1.5	0.23	2.8	4.3	2.9	1.45	0.46	2213EKTNGC3
85	50	14	89	70	129	7	2.0	0.23	2.8	4.3	2.9	2.45	0.46	1313KJJC3
85	65	14	82	72	129	7	2.0	0.39	1.6	2.5	1.7	3.25	0.55	2313KJJC3
98	43	15	92	80	122	7	1.5	0.17	3.6	5.6	3.8	1.35	0.71	1215KTNGC3
98	55	15	90	80	122	13	1.5	0.25	2.5	3.9	2.6	1.60	0.83	2215KJJC3
98	55	15	100	80	149	7	2.0	0.22	2.8	4.4	3.0	3.55	0.83	1315KJJC3
98	73	15	94	82	149	7	2.0	0.38	1.6	2.6	1.7	5.15	1.05	2315KJJC3

# Self-aligning ball bearings

Sealed on both sides  
Bore 12 – 65 mm



Dimensions				Abbreviation		Load ratings		Speed limits
$d_1$	D	B	$r_{1,2}$	Bearing	Sleeve	dyn.	stat.	Grease
Shaft			min			C	$C_0$	
mm						kN		$\text{min}^{-1}$
12	32	14	0.6	2201-2RSTNG	—	5.60	1.27	16,000
15	35	14	0.6	2202-2RSTNG	—	7.50	1.76	15,000
	42	17	1.0	2302-2RSTN	—	9.50	2.28	15,000
17	40	16	0.6	2203-2RSTNG	—	8.00	2.04	14,000
	47	19	1.0	2303-2RSTN	—	12.50	3.20	11,000
20	47	18	1.0	2204-2RSTNG	2204K2RSTNGC3	10.00	2.65	11,000
	52	21	1.1	2304-2RSTNG	2304K2RSTNGC3	12.50	3.35	10,000
25	52	18	1.0	2205-2RSTNG	2205K2RSTNGC3	12.20	3.35	9,500
	62	24	1.1	2305-2RSTNG	2305K2RSTNGC3	18.00	5.00	8,000
30	62	20	1.0	2206-2RSTNG	2206K2RSTNGC3	15.60	4.65	8,000
	72	27	1.1	2306-2RSTNG	2306K2RSTNGC3	21.20	6.30	6,700
35	72	23	1.1	2207-2RSTNG	2207K2RSTNGC3	16.00	5.20	7,000
	80	31	1.5	2307-2RSTNG	2307K2RSTNGC3	25.00	8.00	6,000
40	80	23	1.1	2208-2RSTNG	2208K2RSTNGC3	19.30	6.55	6,300
	90	33	1.5	2308-2RSTNG	2308K2RSTNGC3	29.00	9.65	5,300
45	85	23	1.1	2209-2RSTNG	2209K2RSTNGC3	22.00	7.35	5,600
	100	36	1.5	2309-2RSTNG	2309K2RSTNGC3	38.00	12.90	4,800
50	90	23	1.1	2210-2RSTNG	2210K2RSTNGC3	22.80	8.15	5,300
	100	40	2.0	2310-2RSTNG	2310K2RSTNGC3	41.50	14.30	4,300
55	100	25	1.5	2211-2RSTNG	2211K2RSTNGC3	27.00	10.00	4,800
	120	43	2.0	2311-2RSTNG	2311K2RSTNGC3	51.00	18.00	3,800
60	110	28	1.5	2212-2RSTNG	2212K2RSTNGC3	30.00	11.60	4,300
65	120	31	1.5	2213-2RSTNG	2213K2RSTNGC3	31.00	12.40	4,000

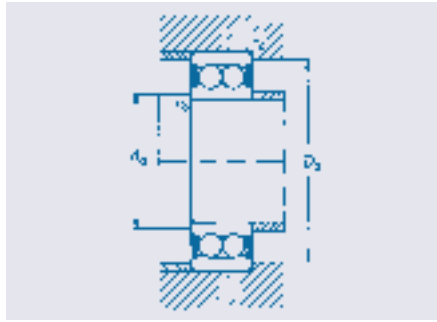
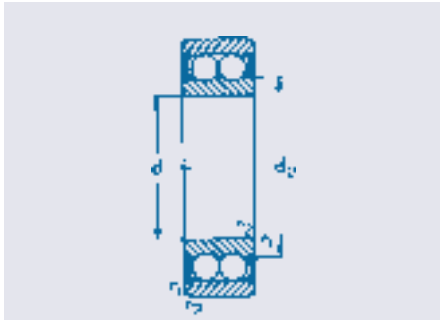

Abutment dimensions			Factors				Weight	Abbreviation
$d_a$ min	$D_a$ max	$r_a$ max	$e$	$Y_1$ $Fa/Fr \leq e$	$Y_2$ $Fa/fr > e$	$Y_0$	$\approx$	
mm							kg	
16.0	28.0	0.6	0.37	1.7	2.6	1.8	0.06	2201-2RSTNG
19.0	31.0	0.6	0.34	1.9	2.9	2.0	0.06	2202-2RSTNG
20.0	37.0	1.0	0.35	1.8	2.8	1.9	0.13	2302-2RSTN
21.0	36.0	0.6	0.33	1.9	3.0	2.0	0.10	2203-2RSTNG
22.0	42.0	1.0	0.32	1.9	3.0	2.0	0.18	2303-2RSTN
25.0	42.0	1.0	0.28	2.2	3.5	2.3	0.16	2204-2RSTNG
26.5	45.5	1.0	0.29	2.2	3.3	2.3	0.24	2304-2RSTNG
30.0	47.0	1.0	0.27	2.4	3.7	2.5	0.17	2205-2RSTNG
31.5	55.5	1.0	0.28	2.3	3.5	2.4	0.38	2305-2RSTNG
35.0	57.0	1.0	0.25	2.5	3.9	2.7	0.28	2206-2RSTNG
36.5	65.5	1.0	0.26	2.4	3.7	2.5	0.57	2306-2RSTNG
41.4	65.5	1.0	0.22	2.8	4.3	2.9	0.45	2207-2RSTNG
43.0	72.0	1.5	0.26	2.5	3.8	2.6	0.79	2307-2RSTNG
46.5	73.5	1.0	0.22	2.9	4.5	3.0	0.55	2208-2RSTNG
48.0	82.0	1.5	0.25	2.5	3.9	2.6	0.05	2308-2RSTNG
51.5	78.5	1.0	0.21	3.0	4.7	3.2	0.58	2209-2RSTNG
53.0	92.0	1.5	0.25	2.5	3.9	2.6	0.40	2309-2RSTNG
56.5	83.5	1.0	0.20	3.2	4.9	3.3	0.63	2210-2RSTNG
59.0	101.0	2.0	0.24	2.6	4.0	2.7	1.89	2310-2RSTNG
63.0	92.0	1.5	0.19	3.3	5.1	3.5	0.76	2211-2RSTNG
66.0	109.0	2.0	0.24	2.7	4.1	2.8	2.37	2311-2RSTNG
68.5	101.5	1.5	0.18	3.5	5.4	3.6	1.11	2212-2RSTNG
74.0	111.0	1.5	0.18	3.6	5.5	3.7	1.53	2213-2RSTNG

# Self-aligning ball bearings

With extended inner ring  
Bore 20 – 60 mm

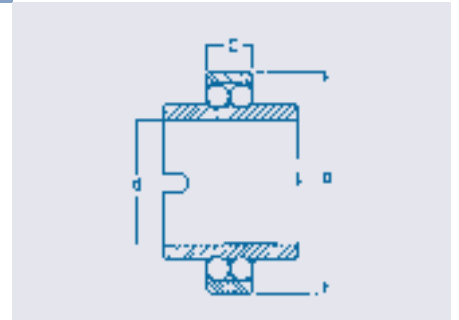

Dimensions				Abbreviation	Load ratings		Speed limits
d	D	C	$r_{1,2}$ min		dyn. C	stat. $C_0$	Grease
mm					kN		$\text{min}^{-1}$
20	47	14	1.0	11204TNG	10.0	2.65	9,000
	52	15	1.0	11304TNG	12.5	3.20	8,500
25	52	15	1.0	11205TNG	12.2	3.35	8,000
	62	17	1.0	11305TNG	18.0	5.00	6,700
30	62	16	1.0	11206TNG	15.6	4.65	6,700
	72	19	1.0	11306TNG	21.2	6.30	5,600
35	72	17	1.1	11207TNG	16.0	5.20	5,600
	80	21	1.1	11307TNG	25.0	8.00	5,000
40	80	18	1.1	11208TNG	19.3	6.55	5,000
	90	23	1.1	11308TNG	29.0	9.65	4,500
45	85	19	1.1	11209TNG	22.0	7.35	4,500
	100	25	1.1	11309TNG	38.0	12.90	3,800
50	90	20	1.1	11210TNG	22.8	8.15	4,300
	110	27	1.1	11310TNG	41.5	14.30	3,600
55	100	21	1.5	11211TNG	27.0	10.00	4,000
60	110	22	1.5	11212TNG	30.0	11.60	3,600

The bore tolerances do not comply with DIN 620. The bore tolerance corresponds to the tolerance zone J7.

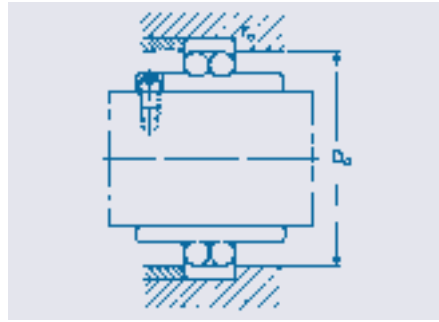
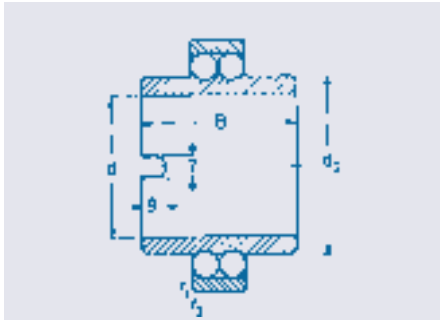

Dimensions		Abutment dimensions		Factors				Weight	Abbreviation
$d_2$	B	$D_a$ max	$r_a$ max	e	$Y_1$ $Fa/Fr \leq e$	$Y_2$ $Fa/fr > e$	$Y_0$	≈	
mm								kg	
29.2	40	42.0	1.0	0.28	2.2	3.5	2.3	0.18	11204TNG
31.5	44	45.5	1.0	0.29	2.2	3.3	2.3	0.28	11304TNG
33.3	44	47.0	1.0	0.27	2.4	3.7	2.5	0.22	11205TNG
38.0	48	55.5	1.0	0.28	2.3	3.5	2.4	0.43	11305TNG
40.1	48	57.0	1.0	0.25	2.5	3.9	2.7	0.35	11206TNG
45.0	52	65.5	1.0	0.26	2.4	3.7	2.5	0.64	11306TNG
47.7	52	65.5	1.0	0.22	2.8	4.3	2.9	0.54	11207TNG
51.7	56	72.0	1.0	0.26	2.5	3.8	2.6	0.85	11307TNG
54.0	56	73.5	1.0	0.22	2.9	4.5	3.0	0.72	11208TNG
57.7	58	82.0	1.0	0.25	2.5	3.9	2.6	1.12	11308TNG
57.7	58	78.5	1.0	0.21	3.0	4.7	3.2	0.77	11209TNG
63.9	60	92.0	1.0	0.25	2.5	3.9	2.6	1.43	11309TNG
62.7	58	83.5	1.0	0.20	3.2	4.9	3.3	0.85	11210TNG
70.3	62	83.5	1.0	0.24	2.6	4.0	2.7	1.82	11310TNG
70.3	60	92.0	1.5	0.19	3.3	5.1	3.5	1.17	11211TNG
78.0	62	102.0	1.5	0.18	3.5	5.4	3.6	1.50	11212TNG

# Self-aligning ball bearings

Sleeve  
Shaft 20 – 50 mm

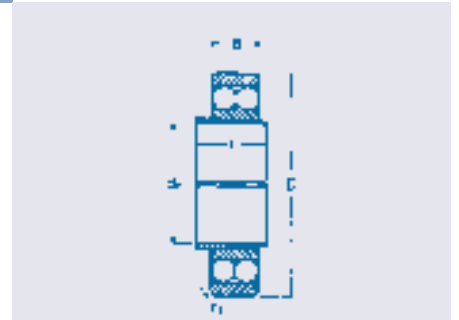

Dimensions						Abbreviation	Load ratings		Speed limits	
Shaft d	$d_h$	D	B	l	$r_{1,2}$ min		dyn. C	stat. $C_0$	Grease	Oil
mm							kN		min <sup>-1</sup>	
20	20	47	14	23	1.0	11504TNGC3	10.0	2.65	15,000	18,000
25	25	52	15	25	1.0	11505TNGC3	12.2	3.35	13,000	16,000
30	30	62	16	25	1.0	11506TNGC3	15.6	4.65	11,000	14,000
35	35	72	17	26	1.1	11507TNGC3	16.0	5.20	9,500	12,000
40	40	80	18	27	1.1	11508TNGC3	19.3	6.55	8,500	10,000
45	45	85	19	28	1.1	11509TNGC3	22.0	7.35	7,500	9,000
50	50	90	20	30	1.1	11510TNGC3	22.8	8.15	7,000	8,500

The bore of the inner ring and its 1:15 taper do not comply with DIN 616.

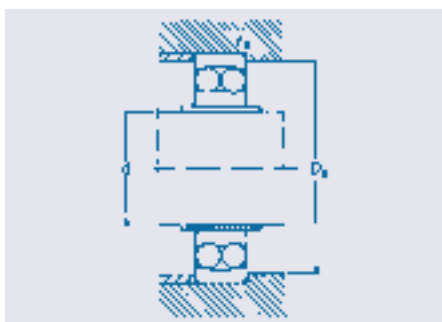

Abutment dimensions		Factors				Weight	Abbreviation
$D_a$ max	$r_a$ max	e	$Y_1$ Fa/Fr ≤ e	$Y_2$ Fa/fr > e	$Y_0$	≈	
mm						kg	
41.0	1.0	0.28	2.2	3.5	2.3	0.120	11504TNGC3
46.5	1.0	0.27	2.4	3.7	2.5	0.144	11505TNGC3
56.5	1.0	0.25	2.5	3.9	2.7	0.227	11506TNGC3
65.0	1.0	0.22	2.8	4.3	2.9	0.335	11507TNGC3
73.0	1.0	0.22	2.9	4.5	3.0	0.435	11508TNGC3
78.0	1.0	0.21	3.0	4.7	3.2	0.480	11509TNGC3
83.0	1.0	0.20	3.2	4.9	3.3	0.540	11510TNGC3

# Deep-groove ball bearings

## Double-row

The structure and operation of double-row deep-groove ball bearings correspond to that of a pair of single-row deep-groove ball bearings. They should not be used where compensation for angular misalignment is required.

### Standards, dimensions

DIN 625 double-row deep-groove ball bearings

### Tolerances

The tolerances are stipulated in DIN 620. Double-row deep-groove ball bearings are only manufactured to standard tolerance P0.

### Bearing clearance

The bearing clearance groups are stipulated in DIN 620 Part 4 or ISO 5753 (see table).

Double-row deep-groove ball bearings are normally supplied with the standard clearance C0 "Normal". Other clearance groups are available on enquiry.

Radial bearing clearance of single and double row deep-groove ball bearings

Rated size of bore d (mm)		Radial clearance in $\mu\text{m}$									
		C2		C0 Standard		C3		C4		C5	
above	up to	min	max	min	max	min	max	min	max	min	max
–	10	0	7	2	13	8	23	14	29	20	37
10	18	0	9	3	18	11	25	18	33	25	45
18	24	0	10	5	20	13	28	20	36	28	48
24	30	1	11	5	20	13	28	23	41	30	53
30	40	1	11	6	20	15	33	28	46	40	64
40	50	1	11	6	23	18	36	30	51	45	73
50	65	1	15	8	28	23	43	38	61	55	90
65	80	1	15	10	30	25	51	46	71	65	105
80	100	1	18	12	36	30	58	53	84	75	120
100	120	2	20	15	41	36	66	61	97	90	140
120	140	2	23	18	48	41	81	71	114	105	160
140	160	2	23	18	53	46	91	81	130	120	180
160	180	2	25	20	61	53	102	91	147	135	200
180	200	2	30	25	71	63	117	107	163	150	230
200	225	4	32	28	82	73	132	120	187	–	–
225	250	4	36	31	92	87	152	140	217	–	–
250	280	4	39	36	97	97	162	152	237	–	–
280	315	8	45	42	110	110	180	175	260	–	–
315	355	8	50	50	120	120	200	200	290	–	–
355	400	8	60	60	140	140	230	230	330	–	–

**Cages** Double-row, deep-groove ball bearings are normally manufactured with snap cages made of glass-fibre reinforced Polyamide 66 and in a few cases, they are also provided with solid brass cages.

M solid cage made of brass, guided in the outer ring

TNG snap cage made of glass-fibre reinforced Polyamide 66

Bearings with cages made of glass-fibre reinforced polyamide are suitable for operating temperatures up to +120°C.

**Weights** The weights shown in the dimension tables apply to the open version of the deep-groove ball bearings.

**Angular adjustment facility** Because of their internal structure, double-row deep-groove ball bearings do not facilitate angular adjustment. When using these bearings, they must not be out of alignment.

**Dynamic equivalent bearing load**

$P = F_r + F_a$  (Double-row deep-groove ball bearings)

With double-row deep-groove ball bearings, it is essential that  $F_a \leq 0.3 \cdot F_r$

**Basic rating life**

$$L_h = \frac{1,000,000}{n \cdot 60} \cdot \left(\frac{C}{P}\right)^3 \quad (\text{Running hours})$$

$$f_h = f_n \cdot \frac{C}{P} \quad (\text{Factors } f_h \text{ and } f_n, \text{ see tables on Page 23})$$

**Static equivalent bearing load**

$P_0 = 0.6 \cdot F_r + 0.5 \cdot F_a$  (Single- and double-rowed deep-groove ball bearings)

If  $P_0 \approx F_r$ , then calculation must be with  $P_0 = F_r$ .

With double-row deep-groove ball bearings, it is essential that  $F_a \leq 0.3 \cdot F_r$ .

**Basic static load rating**

$$s_0 = \frac{C_0}{P_0}$$

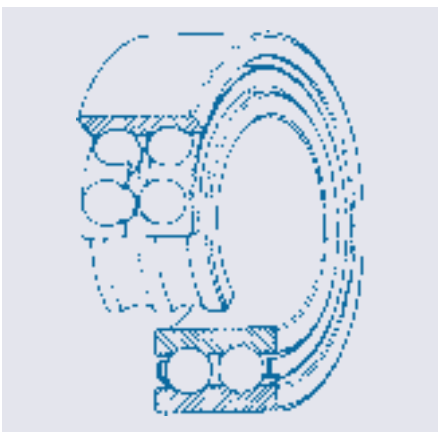

# Deep-groove ball bearings

Double-row  
Bore 10 – 90 mm



Dimensions				Abbreviation	Load ratings		Speed limits	
d	D	B	r <sub>s</sub> min		dyn. C	stat. C <sub>0</sub>	Grease	Oil
mm					kN		min <sup>-1</sup>	
10	30	14	0.6	4200BTNG	9.15	5.2	18,000	24,000
12	32	14	0.6	4201BTNG	9.30	5.5	16,000	20,000
15	35	14	0.6	4202BTNG	10.4	6.7	14,000	18,000
	42	17	1.0	4302BTNG	14.6	9.2	13,000	17,000
17	40	16	0.6	4203BTNG	14.6	9.5	13,000	18,000
	47	19	1.0	4303BTNG	19.6	13.2	11,000	17,000
20	47	18	1.0	4204BTNG	18.0	12.7	10,000	14,000
	52	21	1.1	4304BTNG	23.2	16.0	9,500	13,000
25	52	18	1.0	4205BTNG	19.3	14.6	9,000	12,000
	62	24	1.1	4305BTNG	31.5	22.4	8,000	10,000
30	62	20	1.0	4206BTNG	26.0	20.8	7,500	9,500
	72	27	1.1	4306BTNG	40.0	30.5	6,700	8,500
35	72	23	1.1	4207BTNG	32.0	26.0	6,700	8,500
	80	31	1.5	4307BTNG	51.0	38.0	6,300	8,000
40	80	23	1.1	4208BTNG	34.0	30.0	6,000	7,500
	90	33	1.5	4308BTNG	63.0	48.0	5,600	7,000
45	85	23	1.1	4209BTNG	36.0	33.5	5,600	7,000
	100	36	1.5	4309BTNG	72.0	60.0	4,800	6,000
50	90	23	1.1	4210BTNG	37.5	36.5	5,000	6,300
	110	40	2.0	4310BTNG	90.0	75.0	4,300	5,300
55	100	25	1.5	4211BTNG	43.0	43.0	4,500	5,600
	120	43	2.0	4311BTNG	104.0	90.0	4,000	5,000
60	110	28	1.5	4212BTNG	57.0	58.5	4,000	5,000
	130	46	2.1	4312BTNG	120.0	106.0	3,600	4,500
65	120	31	1.5	4213BTNG	67.0	67.0	3,800	4,800
	140	48	2.1	4313BTNG	129.0	98.0	3,600	4,500
70	125	31	1.5	4214BTNG	69.5	73.5	3,600	4,500
	150	51	2.1	4314BTNG	146.0	114.0	3,200	4,000
75	130	31	1.5	4215BTNG	73.5	80.0	3,400	4,300
	160	55	2.1	4315BTNG	170.0	134.0	3,000	3,800
80	140	33	2.0	4216BTNG	80.0	90.0	3,200	4,000
85	150	36	2.0	4217BTNG	93.0	106.0	3,000	3,800

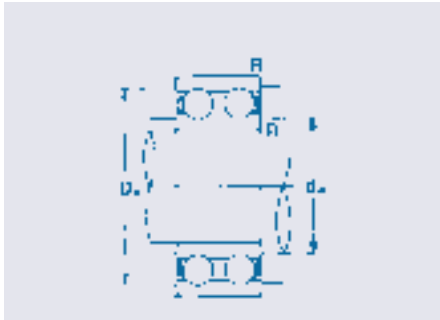

Abutment dimensions			Weight	Abbreviation
$d_a$ min	$D_a$ max	R min	≈	
mm			kg	
14.0	26.0	0.6	0.049	4200BTNG
16.0	28.0	0.6	0.053	4201BTNG
19.0	31.0	0.6	0.059	4202BTNG
20.0	37.0	1.0	0.120	4302BTNG
21.0	36.0	1.0	0.090	4203BTNG
22.0	42.0	1.0	0.16	4303BTNG
25.0	42.0	1.0	0.14	4204BTNG
26.5	45.5	1.0	0.21	4304BTNG
30.0	47.0	1.0	0.16	4205BTNG
31.5	55.5	1.0	0.34	4305BTNG
35.0	57.0	1.0	0.26	4206BTNG
36.5	65.5	1.0	0.50	4306BTNG
41.5	65.5	1.0	0.40	4207BTNG
43.0	72.0	1.5	0.69	4307BTNG
46.5	73.5	1.0	0.50	4208BTNG
48.0	82.0	1.5	0.95	4308BTNG
51.5	78.5	1.0	0.54	4209BTNG
53.0	92.0	1.5	1.25	4309BTNG
56.5	83.5	1.0	0.58	4210BTNG
59.0	101.0	2.0	1.70	4310BTNG
63.0	92.0	1.5	0.80	4211BTNG
64.0	111.0	2.0	2.15	4311BTNG
68.0	102.0	1.5	1.10	4212BTNG
71.0	119.0	2.0	2.65	4312BTNG
73.0	112.0	1.5	1.45	4213BTNG
76.0	129.0	2.0	3.25	4313BTNG
78.0	117.0	1.5	1.50	4214BTNG
81.0	139.0	2.0	3.95	4314BTNG
83.0	122.0	1.5	1.60	4215BTNG
86.0	149.0	2.0	5.38	4315BTNG
89.0	131.0	2.0	2.00	4216BTNG
94.0	141.0	2.0	2.55	4217BTNG
99.0	151.0	2.0	3.20	4218BTNG

# Angular-contact ball bearings

## Double-row

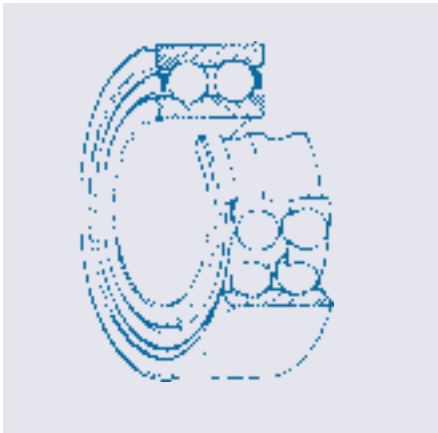

The structure and operation of double-row, angular-contact ball bearings correspond to that of a pair of back-to-back mounted single-row angular-contact ball bearings. They absorb radial and axial forces in both directions. The tilting moments can also be transferred. NSK supplies double-row angular-contact ball bearings with two different contact angles. The Series 32..J and 33..J bearings have a contact angle of 32° and are fitted with a cage made of sheet steel. These bearings have filling slots on one side. The bearings must therefore be installed so that most of the axial force is transferred by the side without the slots.

The Series 32.. and 33.. bearings with the suffix "BTNG" have a contact angle of 25° and are provided with a cage made of glass-fibre reinforced Polyamide 66. These bearings do not have filling slots and can therefore transfer axial forces in both directions.

As well as the open version, NSK supplies double-row angular-contact ball bearings with the suffix "BTNG" also with shield or seals on one or both sides of the bearing. All Series 32..BTNG and 33..BTNG bearings are supplied with grease as standard. The version with the cage made of sheet-steel must be used for operating temperatures above 120°C.

### Standards, dimensions

The external dimensions of double-row angular-contact ball bearings comply with DIN 628.

### Tolerances

The bearings are only manufactured to standard tolerance P0.

### Angular adjustment facility

Double-row angular-contact ball bearings do not facilitate angular adjustment.

### Bearing clearance

The axial clearance of double-row angular-contact ball bearings is specified. The bearings are mass produced with axial clearance C0 "Normal". Other clearance groups are available on enquiry. The axial clearances can be found in the table below.

The radial clearance of Version "BTNG" is approx. 45 % of its axial clearance. The radial clearance of Version "J" is approx. 60 % of its axial clearance.

Axial bearing clearance of double-row angular-contact ball bearings without load

Rated size of bore (mm)	above	6	10	18	24	30	40	50	65	80
	up to	10	18	24	30	40	50	65	80	100
C2	min.	1	1	2	2	2	2	3	3	3
	max.	11	12	14	15	16	18	22	24	26
C0 Standard	min.	5	6	7	8	9	11	13	15	16
	max.	21	23	25	27	29	33	36	40	46
C3	min.	12	13	16	18	21	23	26	30	35
	max.	28	31	34	37	40	44	48	54	63
C4	min.	25	27	28	30	33	36	40	46	55
	max.	45	47	48	50	54	58	63	71	83

Bearing clearances in µm

# Angular-contact ball bearings

## Double-row

**Seals** As well as the open version, NSK manufactures double-row angular-contact ball bearings with the suffix "BTNG" also with shield or seals on one or both sides of the bearing.

**Shields ZR** Shields ZR are sheet-steel discs which are fixed inside the bearing outer ring forming a small gap for the bearing inner ring. The bearings are available with one shield on one side of the bearing "ZR" or shields on both sides of the bearing "2ZR".

**Seals RSR** Seals RSR consist of nitrile rubber and are reinforced with a steel disc embedded in the rubber. The seals are fixed in the outer ring and seal against the inner ring with a friction sealing lip. The bearings are available with one seal on one side of the bearing "RSR" or seals on both sides of the bearing "2RSR".

**Lubrication** With double-row angular-contact ball bearings, the gap between the cage and the rings is relatively small. When lubricating with grease, it is therefore not easy for the user to introduce the grease which is required for the initial lubrication. For this reason, NSK also supplies non-sealed double-row angular-contact ball bearings pre-filled with grease at the factory. The grease which is supplied is a high-quality lithium-based grease with a temperature range of  $-30\text{ }^{\circ}\text{C}$  to  $+120\text{ }^{\circ}\text{C}$ . The grease used by NSK is compatible with all other mineral-oil-based greases.

There is no problem using oil lubrication on bearings which have been lubricated with grease by NSK, providing that the oil used is mineral-oil based. A special version of the bearing is necessary for use with synthetic oils or greases. In these cases, please consult NSK.

### Dynamic equivalent bearing load

With Series 32..BTNG and 33..BTNG:

$$P = F_r + 0.92 \cdot F_a \quad [\text{kN}] \quad \text{where } F_a/F_r \leq 0.68$$

$$P = 0.67 \cdot F_r + 1.41 \cdot F_a \quad [\text{kN}] \quad \text{where } F_a/F_r > 0.68$$

With Series 32..J and 33..J:

$$P = F_r + 0.73 \cdot F_a \quad [\text{kN}] \quad \text{where } F_a/F_r \leq 0.86$$

$$P = 0.62 \cdot F_r + 1.17 \cdot F_a \quad [\text{kN}] \quad \text{where } F_a/F_r > 0.86$$

### Basic rating life

$$L_h = \frac{1,000,000}{n \cdot 60} \cdot \left(\frac{C}{P}\right)^3 \quad (\text{Running hours})$$

$$f_h = f_n \cdot \frac{C}{P} \quad (\text{Factors } f_h \text{ and } f_n, \text{ see tables on Page 39})$$

### Static equivalent bearing load

With Series 32..BTNG and 33..BTNG:

$$P_0 = F_r + 0.76 \cdot F_a \quad [\text{kN}]$$

With Series 32..J and 33..J:

$$P_0 = F_r + 0.63 \cdot F_a \quad [\text{kN}]$$

### Basic static load rating

$$S_0 = \frac{C_0}{P_0}$$

# Angular-contact ball bearings

Double-row  
Bore 10 – 75 mm

Open

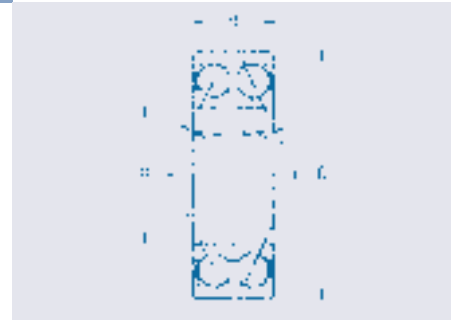

Dimensions				Abbreviation			Load ratings		Speed limits	
d	D	B	r <sub>1,2</sub> min	open	with shields	with seals	dyn. C	stat. C <sub>0</sub>	Grease	Oil
mm							kN		min <sup>-1</sup>	
10	30	14.0	0.6	3200BTNG	..B2ZRTNG	..B2RSRTNG	7.80	4.55	16000	22000
12	32	15.9	0.6	3201BTNG	..B2ZRTNG	..B2RSRTNG	10.60	5.85	15000	20000
	37	19.0	1.0	3301BTNG	..B2ZRTNG	..B2RSRTNG	14.50	8.20	10500	11500
15	35	15.9	0.6	3202BTNG	..B2ZRTNG	..B2RSRTNG	11.80	7.10	14000	19000
	42	19.0	1.0	3302BTNG	..B2ZRTNG	..B2RSRTNG	16.30	10.00	11000	16000
17	40	17.5	0.6	3203BTNG	..B2ZRTNG	..B2RSRTNG	14.60	9.00	12000	17000
	47	22.2	1.0	3303BTNG	..B2ZRTNG	..B2RSRTNG	20.80	12.50	10000	15000
20	47	20.6	1.0	3204BTNG	..B2ZRTNG	..B2RSRTNG	19.60	12.50	10000	15000
	52	22.2	1.1	3304BTNG	..B2ZRTNG	..B2RSRTNG	23.20	15.00	9000	13000
25	52	20.6	1.0	3205BTNG	..B2ZRTNG	..B2RSRTNG	21.20	14.60	8500	12000
	62	25.4	1.1	3305BTNG	..B2ZRTNG	..B2RSRTNG	30.00	20.00	7500	10000
30	62	23.8	1.0	3206BTNG	..B2ZRTNG	..B2RSRTNG	30.00	21.20	7000	9500
	72	30.2	1.1	3306BTNG	..B2ZRTNG	..B2RSRTNG	41.50	28.50	6300	8500
35	72	27.0	1.1	3207BTNG	..B2ZRTNG	..B2RSRTNG	39.00	28.50	6300	8500
	80	34.9	1.5	3307BTNG	..B2ZRTNG	..B2RSRTNG	51.00	34.50	5600	7500
40	80	30.2	1.1	3208BTNG	..B2ZRTNG	..B2RSRTNG	48.00	36.50	5600	7500
	90	36.5	1.5	3308BTNG	..B2ZRTNG	..B2RSRTNG	62.00	45.00	5000	6700
45	85	30.2	1.1	3209BTNG	..B2ZRTNG	..B2RSRTNG	48.00	37.50	5000	6700
	100	39.7	1.5	3309BTNG	..B2ZRTNG	..B2RSRTNG	68.00	51.00	4500	6000
50	90	30.2	1.1	3210BTNG	..B2ZRTNG	..B2RSRTNG	51.00	42.50	4800	6300
	110	44.4	2.0	3310BTNG	..B2ZRTNG	..B2RSRTNG	81.00	62.00	4000	5300
55	100	33.3	1.5	3211BTNG	..B2ZRTNG	..B2RSRTNG	58.50	49.00	4300	5600
	120	49.2	2.0	3311BTNG	..B2ZRTNG	..B2RSRTNG	102.00	78.00	3800	5000
60	110	36.5	1.5	3212BTNG	..B2ZRTNG	..B2RSRTNG	72.00	61.00	3800	5000
	130	54.0	2.1	3312BTNG	..B2ZRTNG	..B2RSRTNG	125.00	98.00	3400	4500
65	120	38.1	1.5	3213BTNG	..B2ZRTNG	..B2RSRTNG	80.00	73.50	3400	4500
	140	58.7	2.1	3313BTNG	..B2ZRTNG	..B2RSRTNG	150.00	118.00	3200	4300
70	125	39.7	1.5	3214BTNG	..B2ZRTNG	..B2RSRTNG	83.00	76.50	3400	4500
	150	63.5	2.1	3314BTNG	..B2ZRTNG	..B2RSRTNG	171.50	138.20	3000	4000
75	130	41.3	1.5	3215BTNG	..B2ZRTNG	..B2RSRTNG	91.50	85.00	3200	4300
	160	63.5	2.1	3315BTNG	..B2ZRTNG	..B2RSRTNG	173.40	145.30	2800	3800

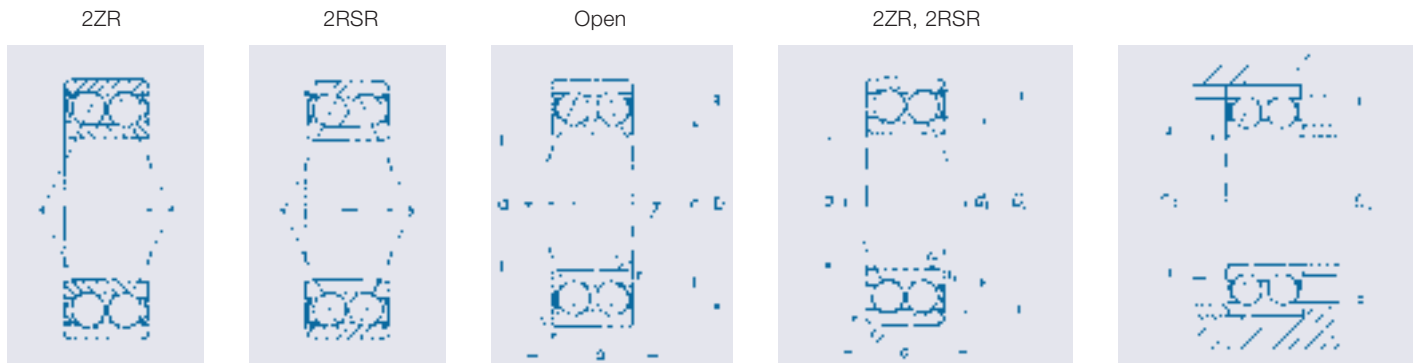

Dimensions			Abutment dimensions			Weight	Abbreviation
$d_1$	$D_1, D_2$	$a$	$d_a$	$D_a$	$r_a$	$\approx$	
$\approx$	$\approx$		min	max	max		
mm						kg	
17.9	23.9	15.1	15	25	0.6	0.043	3200BTNG
18.3	25.7	16.6	17	27	0.6	0.051	3201BTNG
21.1	30.4	19.4	19	32	1.0	0.090	3301BTNG
21.0	29.3	18.0	20	30	0.6	0.058	3202BTNG
25.6	34.2	21.2	21	36	1.0	0.112	3302BTNG
24.0	33.1	20.5	22	35	0.6	0.085	3203BTNG
26.2	37.7	24.0	23	41	1.0	0.161	3303BTNG
28.9	38.7	24.2	26	41	1.0	0.139	3204BTNG
31.2	42.6	26.4	27	45	1.0	0.197	3304BTNG
33.9	43.7	26.5	31	46	1.0	0.159	3205BTNG
37.1	50.0	30.7	32	55	1.0	0.316	3305BTNG
40.0	52.7	31.4	36	56	1.0	0.265	3206BTNG
44.0	59.0	36.2	37	65	1.0	0.496	3306BTNG
47.2	60.4	36.6	42	65	1.0	0.412	3207BTNG
49.2	65.4	41.5	44	71	1.5	0.664	3307BTNG
52.9	67.9	40.9	47	73	1.0	0.550	3208BTNG
55.4	74.3	46.1	49	81	1.5	0.905	3308BTNG
57.1	72.6	43.2	52	78	1.0	0.583	3209BTNG
62.2	81.6	50.0	54	91	1.5	1.210	3309BTNG
61.9	78.1	45.5	57	83	1.0	0.632	3210BTNG
68.2	89.6	54.9	60	100	2.0	1.600	3310BTNG
68.6	85.3	49.9	64	91	1.5	0.876	3211BTNG
75.2	98.4	61.2	65	110	2.0	2.110	3311BTNG
75.7	94.3	55.1	69	101	1.5	1.180	3212BTNG
81.2	108.7	67.3	72	118	2.0	2.700	3312BTNG
84.5	103.5	59.8	74	111	1.5	1.520	3213BTNG
88.2	118.0	73.3	77	128	2.0	3.390	3313BTNG
86.7	106.2	61.6	79	116	1.5	1.640	3214BTNG
94.7	125.0	80.8	84	135	2.1	4.900	3314BTNG
92.4	112.6	65.0	89	116.6	1.5	1.910	3215BTNG
101.4	133.0	83.8	90	143.0	2.1	5.700	3315BTNG

# Angular-contact ball bearings

Double-row  
Bore 80 – 90 mm

Open



Dimensions				Abbreviation			Load ratings		Speed limits	
d	D	B	r <sub>1,2</sub> min	open	with shields	with seals	dyn. C	stat. C <sub>0</sub>	Grease	Oil
mm							kN		min <sup>-1</sup>	
80	140	44.4	2.0	3216BTNG	..B2ZRTNG	..B2RSRTNG	98.0	93.0	3000	4000
85	150	49.2	2.0	3217BTNG	..B2ZRTNG	..B2RSRTNG	116.0	110.0	2800	3800
90	160	52.4	2.0	3218BTNG	..B2ZRTNG	..B2RSRTNG	124.6	120.3	2600	3600

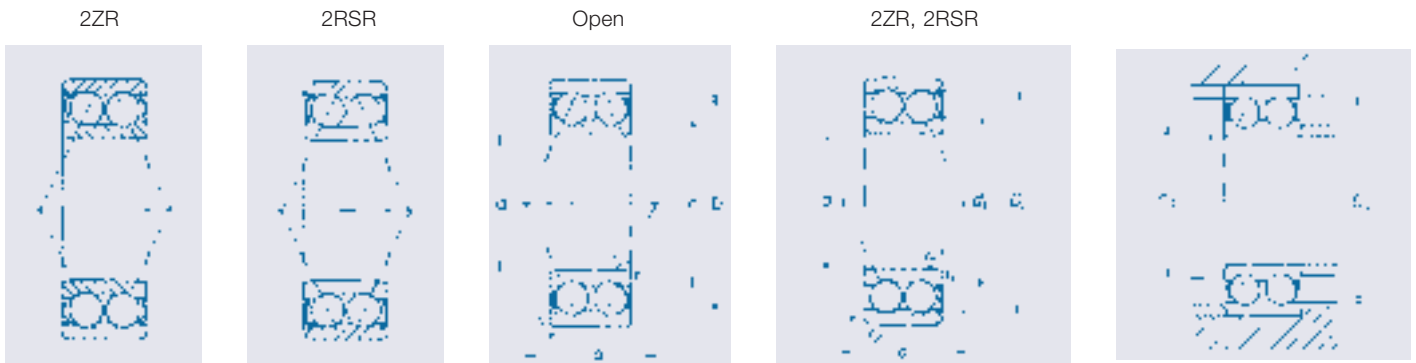

Dimensions			Abutment dimensions			Weight	Abbreviation
$d_1$	$D_1, D_2$	$a$	$d_a$	$D_a$	$r_a$	$\approx$	
$\approx$	$\approx$		min	max	max		
mm						kg	
98.5	120.3	69.0	91	129	2.0	2.450	3216BTNG
106.4	128.5	74.6	100	135	2.0	3.300	3217BTNG
113.2	136.6	78.9	109	141	2.1	4.170	3218BTNG

# Angular-contact ball bearings

Double-row, with filling slot  
Bore 10 – 70 mm



Main dimensions				Abbreviation	Load ratings		Speed limits	
d	D	B	$r_{1,2}$ min		dyn. C	stat. C <sub>0</sub>	Lubrication Grease	Oil
mm					kN		min <sup>-1</sup>	
10	30	14.0	0.6	3200J	8.0	5.9	17000	24000
12	32	15.9	0.6	3201J	9.5	7.1	15000	20000
15	35	15.9	0.6	3202J	10.8	9.0	13000	18000
	42	19.0	1.0	3302J	14.5	12.3	12000	17000
17	40	17.5	0.6	3203J	12.6	10.8	12000	17000
	47	22.2	1.0	3303J	20.7	16.7	10000	15000
20	47	20.6	1.0	3204J	17.2	15.3	10000	15000
	52	22.2	1.1	3304J	20.8	18.5	9500	14000
25	52	20.6	1.0	3205J	19.0	18.5	8500	12000
	62	25.4	1.1	3305J	28.9	26.7	7500	10000
30	62	23.8	1.0	3206J	27.2	27.3	7000	9500
	72	30.2	1.1	3306J	38.1	36.5	6300	8500
35	72	27.0	1.1	3207J	36.8	38.0	6300	8500
	80	34.9	1.5	3307J	48.5	47.5	5600	7500
40	80	30.2	1.1	3208J	42.0	44.8	5600	7500
	90	36.5	1.5	3308J	59.8	64.8	4800	6300
45	85	30.2	1.1	3209J	45.4	52.1	5000	6700
	100	39.7	1.5	3309J	73.1	80.9	4300	5600
50	90	30.2	1.1	3210J	48.2	56.0	4800	6300
	110	44.4	2.0	3310J	87.6	98.3	4000	5300
55	100	33.3	1.5	3211J	55.7	69.9	4300	5600
	120	49.2	2.0	3311J	100.5	115.3	3600	4800
60	110	36.5	1.5	3212J	71.4	86.1	3800	5000
	130	54.0	2.1	3312J	116.1	135.3	3400	4500
65	120	38.1	1.5	3213J	76.4	98.4	3600	4800
	140	58.7	2.1	3313J	133.7	156.4	3200	4300
70	125	39.7	1.5	3214J	84.2	109.5	3200	4300
	150	63.5	2.1	3314J	146.9	175.5	2800	3800

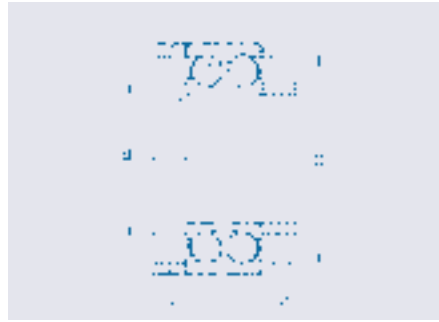
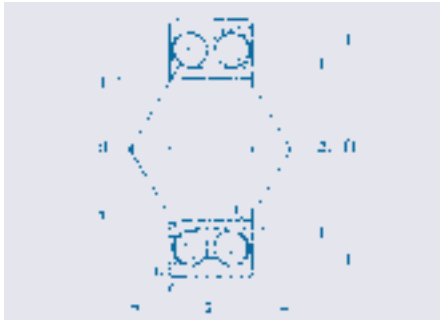

Dimensions			Abutment dimensions			Weight	Abbreviation
$d_1$ ≈	$D_1$ ≈	a	$d_a$ min	$D_a$ max	$r_a$ max	≈	
mm						kg	
17.2	24.4	20	14	26	0.6	0.052	3200J
19.3	26.9	22	16	28	0.6	0.063	3201J
22.6	30.4	24	19	31	0.6	0.072	3202J
24.9	34.4	27	21	36	1.0	0.132	3302J
25.5	33.8	27	21	36	0.6	0.103	3203J
27.6	40.0	31	23	41	1.0	0.192	3303J
29.5	40.5	32	26	41	1.0	0.168	3204J
32.0	43.0	34	27	45	1.0	0.230	3304J
34.6	45.1	35	31	46	1.0	0.194	3205J
38.5	52.5	40	32	55	1.0	0.369	3305J
41.2	54.0	41	36	56	1.0	0.316	3206J
45.4	61.3	47	37	65	1.0	0.585	3306J
47.8	63.3	47	42	65	1.0	0.484	3207J
50.8	69.2	54	44	71	1.5	0.816	3307J
54.0	70.4	53	47	73	1.0	0.654	3208J
59.4	80.1	59	49	81	1.5	1.070	3308J
59.8	76.4	56	52	78	1.0	0.709	3209J
66.2	89.1	64	54	91	1.5	1.400	3309J
63.7	80.8	59	57	83	1.0	0.764	3210J
72.5	96.4	73	60	100	2.0	1.950	3310J
72.0	89.7	64	64	91	1.5	1.050	3211J
80.2	106.4	80	65	110	2.0	2.550	3311J
78.2	98.3	71	69	101	1.5	1.400	3212J
86.2	115.0	86	72	118	2.0	3.250	3312J
84.7	105.8	76	74	111	1.5	1.750	3213J
92.5	123.0	94	77	128	2.0	4,100	3313J
88.7	111.5	81	79	116	1.5	1.900	3214J
98.5	131.0	101	82	138	2.0	5.050	3314J

# Pulleys

Pulleys are developments of double-row angular-contact ball bearings with a reinforced outer ring. The outer ring can be either of cylindrical or spherical design. The inner ring of these bearings is provided with lubrication holes. The bearings have no filling slot and absorb radial and axial forces in both directions. The contact angle of these bearings is 25°. The bearing cage is made of glass-fibre reinforced Polyamide 66. Pulleys are supplied with seals or shields on both sides. They are normally supplied filled with grease at the factory. Special pulleys with galvanised bearing inner and outer rings are also available on enquiry.

**Tolerances** The bearings are only manufactured to the standard tolerance P0.

**Angular adjustment facility** Double-row pulleys do not facilitate angular adjustment.

**Bearing clearance** With double-row pulleys, the axial bearing clearance is specified. The bearings are normally supplied with axial clearance C0 "Normal". The axial clearances can be found in the table below.

The radial clearances are approx. 45 % of the axial clearances.

## Axial clearance of double-row pulleys without load

Rated size of bore (mm)	above	6	10	18	24	30	40	50	65
	up to	10	18	24	30	40	50	65	80
C0 Standard	min.	5	6	7	8	9	11	13	15
	max.	21	23	25	27	29	33	36	40

Bearing clearances in µm

**Cages** Double-row pulleys are fitted with cages made of glass-fibre reinforced Polyamide 66.

**Seals** NSK manufactures pulleys with seals and shields on both sides of the bearing.

**Shields ZR** Shields are sheet-steel discs which are fixed inside the bearing outer ring forming a small gap for the bearing inner ring. The bearings are available with shields on both sides "2ZR".

**Seals RSR** Seals RSR consist of nitrile rubber and are reinforced with a steel disc embedded in the rubber. The seals are fixed in the outer ring and seal against the inner ring with a friction sealing lip. The bearings are available with seals on both sides of the bearing "2RSR".

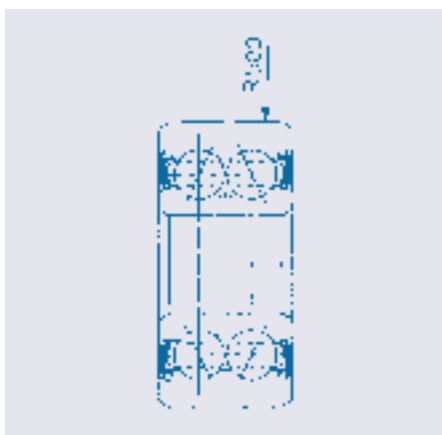

### Lubrication

NSK supplies pulleys filled with grease at the factory. This is a high-quality lithium-based grease with an admissible temperature range of  $-30\text{ }^{\circ}\text{C}$  to  $+110\text{ }^{\circ}\text{C}$ . The grease used by NSK is compatible with all other mineral-oil-based greases. The inner rings of the pulleys are provided with a lubrication hole so that bearings can be re-lubricated. With Version 2RSR, the grease must be pressed in slowly to avoid damaging the seals.

### Bearing load capacity

If the pulley is supported by a flat contact surface, only a small surface area of the outer ring of the pulleys comes into contact with the rolling plane. The elastic deformation of the outer ring reduces the load-bearing capacity of the pulley. In this case, the values specified in the "Pulley load ratings" table must be used in the calculation. On the other hand, when installing the pulley in a housing bore, the "Bearing load ratings" apply which are also listed.

### Suffixes

LZ	Pulley with cylindrical outer ring (prefix)
LB	Pulley with spherical outer ring (prefix)
B	$25^{\circ}$ Contact angle
S	Lubrication hole in inner ring
TNG	Cage made of glass-fibre reinforced Polyamide 66
2ZR	Shields on both sides
2RSR	Seals on both sides

### Dynamic equivalent bearing load

$$P = F_r + 0.92 \cdot F_a \quad [\text{kN}] \quad \text{where } F_a/F_r \leq 0.68$$

$$P = 0.67 \cdot F_r + 1.41 \cdot F_a \quad [\text{kN}] \quad \text{where } F_a/F_r > 0.68$$

### Basic rating life

$$L_n = \frac{1,000,000}{n \cdot 60} \cdot \left(\frac{C}{P}\right)^3 \quad (\text{Running hours})$$

$$f_h = f_n \cdot \frac{C}{P} \quad (\text{Factors } f_h \text{ and } f_n \text{ see Table Page 39})$$

### Static equivalent bearing load

$$P_0 = F_r + 0.76 \cdot F_a \quad [\text{kN}]$$

### Basic static load rating

$$s_0 = \frac{C_0}{P_0}$$

# Pulleys

LZ..2ZR

Pulleys  
Bore 10 – 35 mm



Dimensions				Abbreviation		Load ratings [kN]				Speed limits	Weight		
d	D*	B	r <sub>s</sub>	Shields	Seals	Bearing Pulley		dyn.	stat.	dyn.		stat.	≈
mm			min			C	C <sub>0</sub>	C	C <sub>0</sub>			min <sup>-1</sup>	kg
10	32	14.0	0.6	LZ3200B2ZRSTNG LB3200B2ZRSTNG	LZ3200B2RSRSTNG LB3200B2RSRSTNG	7.8	4.55	7.45	4.15	16000		0.061	
12	35	15.9	0.6	LZ3201B2ZRSTNG LB3201B2ZRSTNG	LZ3201B2RSRSTNG LB3201B2RSRSTNG	10.6	5.85	9.95	5.20	15000		0.079	
15	40	15.9	0.6	LZ3202B2ZRSTNG LB3202B2ZRSTNG	LZ3202B2RSRSTNG LB3202B2RSRSTNG	11.8	7.10	11.00	6.45	13000		0.100	
17	47	17.5	0.6	LZ3203B2ZRSTNG LB3203B2ZRSTNG	LZ3203B2RSRSTNG LB3203B2RSRSTNG	14.6	9.00	13.80	8.30	10000		0.165	
20	52	20.6	1.0	LZ3204B2ZRSTNG LB3204B2ZRSTNG	LZ3204B2RSRSTNG LB3204B2RSRSTNG	19.6	12.50	18.30	11.00	9000		0.210	
25	62	20.6	1.0	LZ3205B2ZRSTNG LB3205B2ZRSTNG	LZ3205B2RSRSTNG LB3205B2RSRSTNG	21.2	14.60	19.90	13.40	8000		0.330	
30	72	23.8	1.0	LZ3206B2ZRSTNG LB3206B2ZRSTNG	LZ3206B2RSRSTNG LB3206B2RSRSTNG	30.0	21.20	27.90	18.60	7100		0.500	
35	80	27.0	1.1	LZ3207B2ZRSTNG LB3207B2ZRSTNG	LZ3207B2RSRSTNG LB3207B2RSRSTNG	39.0	28.50	36.2	25.0	6300		0.660	

\* with spherical outer ring D 0.05 mm

LZ..2RSR

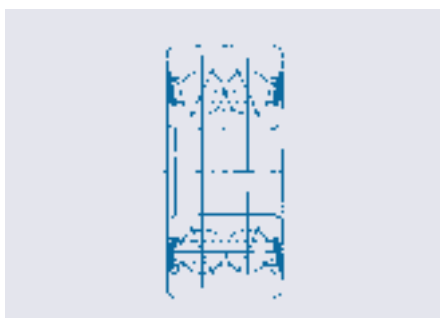

LB..2ZR



LB..2RSR



# Life factors $f_h$ and speed factors $f_n$ for ball bearings

$f_h$  values for ball bearings  $f_h = \sqrt[3]{\frac{L_h}{500}}$

$L_h$ (h)	$f_h$	$L_h$ (h)	$f_h$	$L_h$ (h)	$f_h$	$L_h$ (h)	$f_h$	$L_h$ (h)	$f_h$
100	0.585	400	0.928	1,500	1.440	5,000	2.150	20,000	3.420
110	0.604	420	0.944	1,600	1.470	5,500	2.220	22,000	3.530
120	0.621	440	0.958	1,700	1.500	6,000	2.290	24,000	3.630
130	0.638	460	0.973	1,800	1.530	6,500	2.350	26,000	3.730
140	0.654	480	0.986	1,900	1.560	7,000	2.410	28,000	3.830
150	0.669	500	1.000	2,000	1.590	7,500	2.470	30,000	3.910
160	0.684	550	1.030	2,200	1.640	8,000	2.520	35,000	4.120
170	0.698	600	1.060	2,400	1.690	8,500	2.570	40,000	4.310
180	0.711	650	1.090	2,600	1.730	9,000	2.620	45,000	4.480
190	0.724	700	1.120	2,800	1.780	9,500	2.670	50,000	4.640
200	0.737	750	1.140	3,000	1.820	10,000	2.710	55,000	4.790
220	0.761	800	1.170	3,200	1.860	11,000	2.800	60,000	4.930
240	0.783	850	1.190	3,400	1.890	12,000	2.880	65,000	5.070
260	0.804	900	1.220	3,600	1.930	13,000	2.960	70,000	5.190
280	0.824	950	1.240	3,800	1.970	14,000	3.040	75,000	5.310
300	0.843	1,000	1.260	4,000	2.000	15,000	3.110	80,000	5.430
320	0.862	1,100	1.300	4,200	2.030	16,000	3.170	85,000	5.540
340	0.879	1,200	1.340	4,400	2.060	17,000	3.240	90,000	5.650
360	0.896	1,300	1.380	4,600	2.100	18,000	3.300	95,000	5.750
380	0.913	1,400	1.410	4,800	2.130	19,000	3.360	100,000	5.850

$f_n$  - values for ball bearings  $f_n = \sqrt[3]{\frac{33^{1/3}}{n}}$

$n$ (min <sup>-1</sup> )	$f_n$	$n$ (min <sup>-1</sup> )	$f_n$	$n$ (min <sup>-1</sup> )	$f_n$	$n$ (min <sup>-1</sup> )	$f_n$	$n$ (min <sup>-1</sup> )	$f_n$
10	1.490	50	0.874	300	0.481	1,500	0.281	7,500	0.1640
11	1.450	55	0.846	320	0.471	1,600	0.275	8,000	0.1610
12	1.410	60	0.822	340	0.461	1,700	0.270	8,500	0.1580
13	1.370	65	0.800	360	0.452	1,800	0.265	9,000	0.1550
14	1.340	70	0.781	380	0.444	1,900	0.260	9,500	0.1520
15	1.300	75	0.763	400	0.437	2,000	0.255	10,000	0.1490
16	1.280	80	0.747	420	0.430	2,200	0.247	11,000	0.1450
17	1.250	85	0.732	440	0.423	2,400	0.240	12,000	0.1410
18	1.230	90	0.718	460	0.417	2,600	0.234	13,000	0.1370
19	1.210	95	0.705	480	0.411	2,800	0.228	14,000	0.1340
20	1.190	100	0.693	500	0.405	3,000	0.223	16,000	0.1280
22	1.150	110	0.672	550	0.393	3,200	0.218	18,000	0.1230
24	1.120	120	0.652	600	0.382	3,400	0.214	20,000	0.1190
26	1.090	130	0.635	650	0.372	3,600	0.210	22,000	0.1150
28	1.060	140	0.620	700	0.362	3,800	0.206	24,000	0.1120
30	1.040	150	0.606	750	0.354	4,000	0.203	26,000	0.1090
32	1.010	160	0.593	800	0.347	4,200	0.199	28,000	0.1060
34	0.993	170	0.581	850	0.340	4,400	0.196	30,000	0.1040
36	0.975	180	0.570	900	0.333	4,600	0.194	32,000	0.1010
38	0.957	190	0.560	950	0.327	4,800	0.191	34,000	0.0993
40	0.941	200	0.550	1,000	0.322	5,000	0.188	36,000	0.0975
42	0.926	220	0.533	1,100	0.312	5,500	0.182	38,000	0.0957
44	0.912	240	0.518	1,200	0.303	6,000	0.177	40,000	0.0941
46	0.898	260	0.504	1,300	0.295	6,500	0.172	45,000	0.0905
48	0.886	280	0.492	1,400	0.288	7,000	0.168	50,000	0.0875



## EUROPEAN SALES OFFICES AND JAPAN

### GERMANY

NSK DEUTSCHLAND GMBH  
HARKORTSTRASSE 15  
40880 RATINGEN  
TEL: +49/ 2102 4810  
FAX: +49/ 2102 4812290  
E-mail: info-de@nsk.com

### England

NSK UK LTD.  
NORTHERN ROAD, NEWARK  
NOTTINGHAMSHIRE, NG24 2JF  
TEL: +44/ 1636 605123  
FAX: +44/ 1636 602775  
E-mail: info-uk@nsk.com

### FRANCE

NSK FRANCE S.A.  
QUARTIER DE L'EUROPE  
2 RUE GEORGES, GUYNEMER  
78283 GUYANCOURT, CEDEX  
TEL: +33/ 1 305 73939  
FAX: +33/ 1 305 70001  
E-mail: info-fr@nsk.com

### ITALY

NSK ITALIA S.P.A.  
VIA GARIBALDI 215  
20024 GARBAGNATE  
MILANESE (MILAN)  
TEL: +39/ 02 995 191  
FAX: +39/ 02 9902 5578  
E-mail: info-it@nsk.com

### POLAND

NSK ISKRA S.A.  
SALES AND MARKETING OFFICE  
UL. WARSZAWSKA 146, 25-547 KIELCE  
TEL: +48/ 41 36 70 505  
FAX: +48/ 41 36 70 500  
E-mail: info-pl@nsk.com

### SPAIN

NSK SPAIN, S.A.  
C/ TARRAGONA, 161 CUERPO BAJO  
2A PLANTA, 08014 BARCELONA  
TEL: +34/ 932 89 27 63  
Fax: +34/ 934 33 57 76  
E-mail: info-es@nsk.com

### SCANDINAVIA

NSK NORGE OFFICE  
STRE KULLERD 5  
N-3241 SANDEFJORD  
TEL: +47/ 3329 3160  
FAX: +47/3342 9002  
E-mail: info-n@nsk.com

### TURKEY

NSK RULMANLARI ORTA DOÚU TIC. LTD. TI.  
YALI MAH. FEVZI CAKMAK CAD.  
CAGLAR APT. NO 11/4  
MALTEPE, ISTANBUL, 34844  
TEL: +90/ 216 442 7106  
FAX: +90/ 216 305 5505  
E-mail: turkey@nsk.com

### Japan

NSK JAPAN LTD.  
NISSEI BLDG., 6-3  
OHSAKI 1-CHOME SHINAGAWA-KU  
TOKYO 141-8560  
TEL: +81/ 3 3779 7680  
FAX: +81/ 3 3779 7433

Please also visit our website: [www.eu.nsk.com](http://www.eu.nsk.com)